



REPLACEMENT IGNITION SYSTEM FOR
AGBQ-27G SERIAL #'s 30000 TO 30499 &
AGBQ-27XL SERIAL #'s 40000 TO 40489

- This 3 Spark module is intended to replace the existing 4 or 2 Spark module currently fitted to your AGBQ-27XL or AGBQ-27G Grill with a Serial # within the range specified above.
- After removing the existing 4 or 2 spark module from the Front Control Panel mounting bracket, slightly bend down the bracket to allow free access of the replacement 3 Spark Module
- For Model **AGBQ-27G** you will need to add the Ground cable provided to the front face of the Firebox as shown in Fig. 1a & Fig1.
- For Model **AGBQ-27XL** you will discard the existing Ground cable as it is no longer required. Fig.2
- Remove the Push Button Cap and Retaining Nut from the new 3 spark Module.
- Push the threaded mounting flange of the new 3 Spark Module through the existing hole in the Front Control Panel and secure the unit with the Retaining Nut.
- Note that the new 3 Spark Module will only fit in one orientation, Main body of the unit to the top. Fig.3.
- Connect the 3 wires to the back of the new 3 Spark Module ensuring that they are a tight fit.
- Fit a New 1 ½ volt battery into the 3 Spark Module (Negative End First) and secure with the screw on Push Button Cap. Fig. 4
- Test the unit for correct operation before replacing the front Control Panel.
- Refit the front control panel and check the unit for correct operation again to ensure that the wires have not become disconnected.

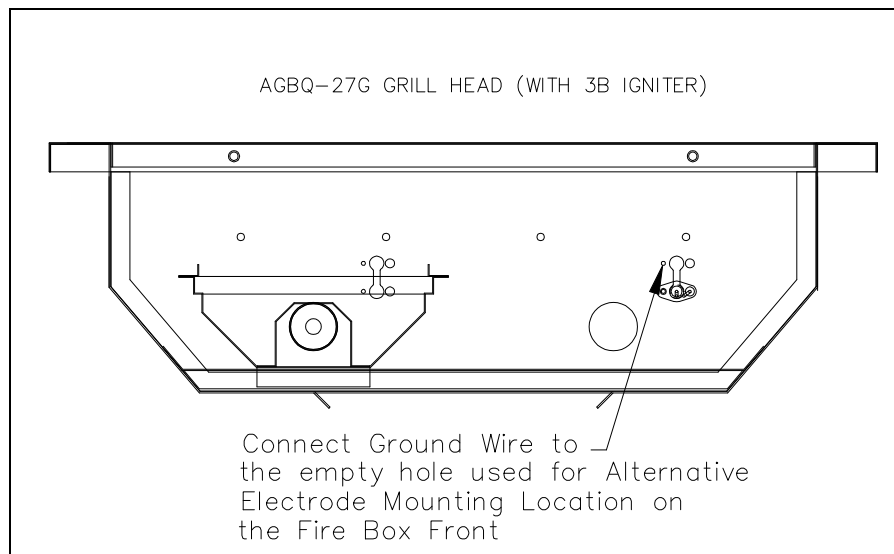

Fig 1a.

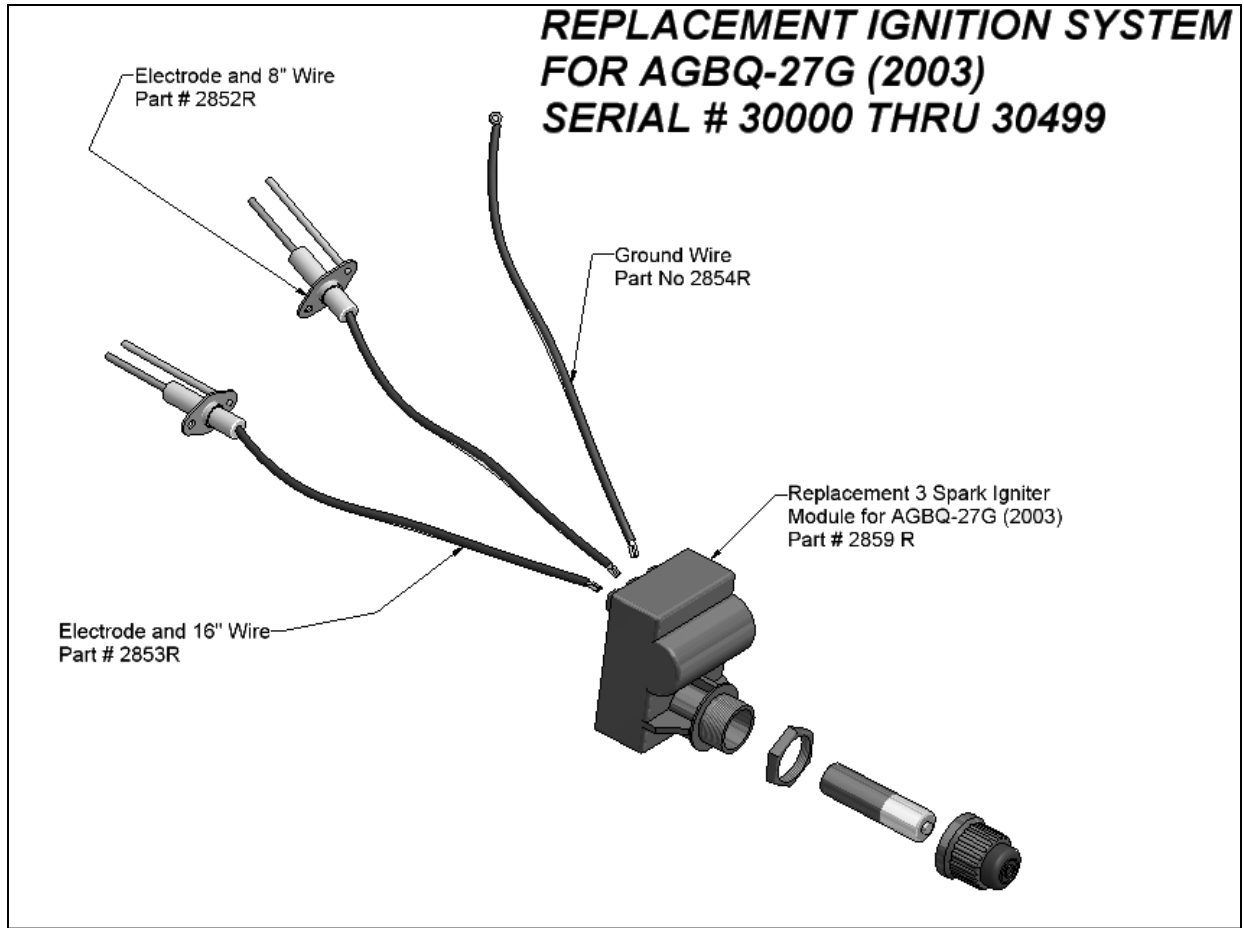

Fig 1

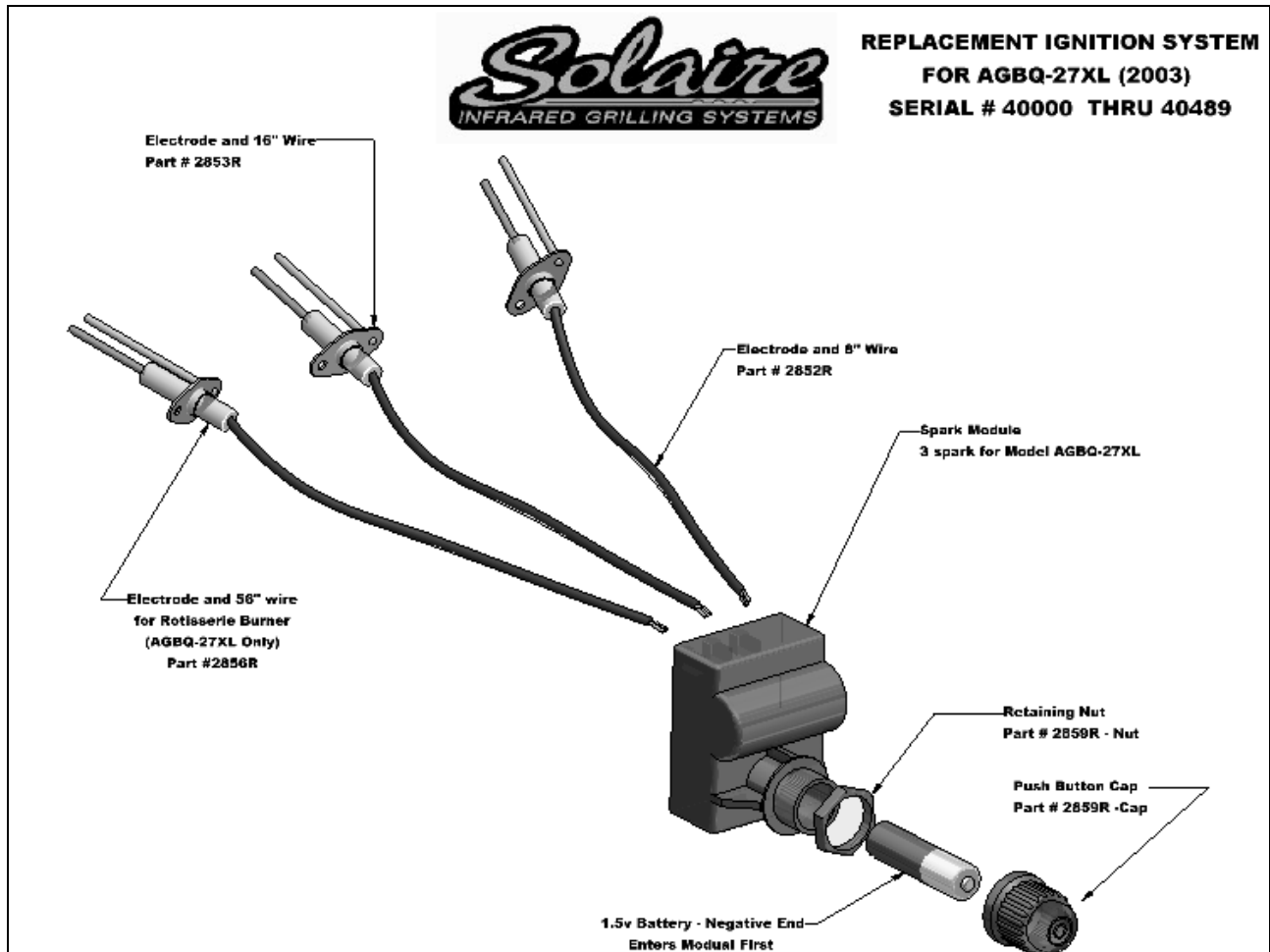

Fig 2.

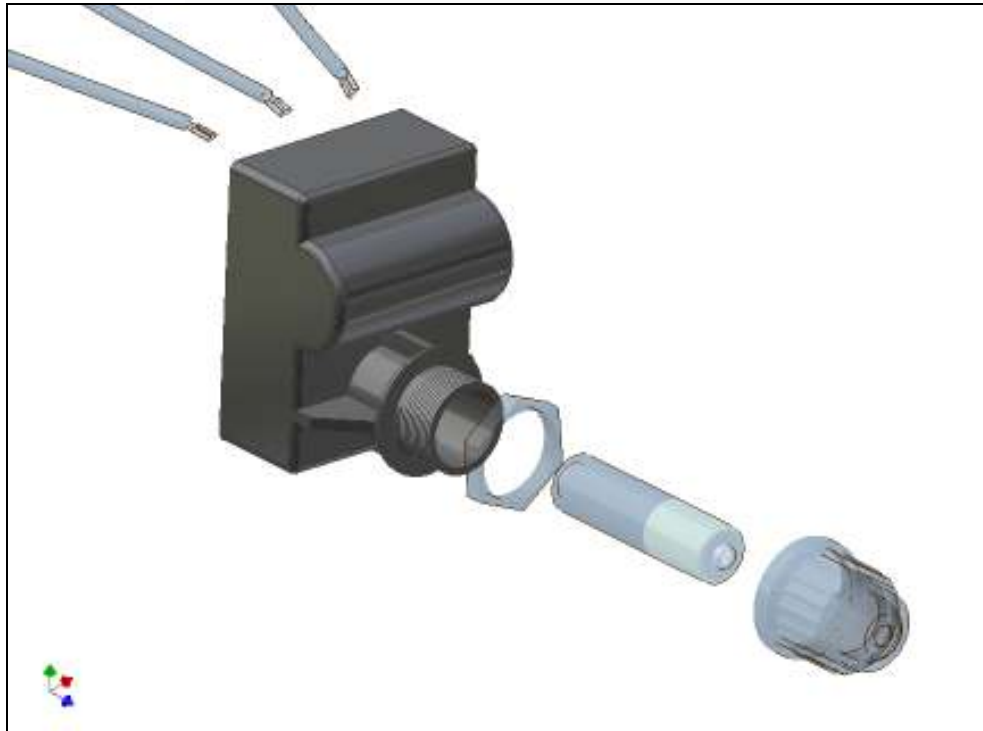

Fig 3.

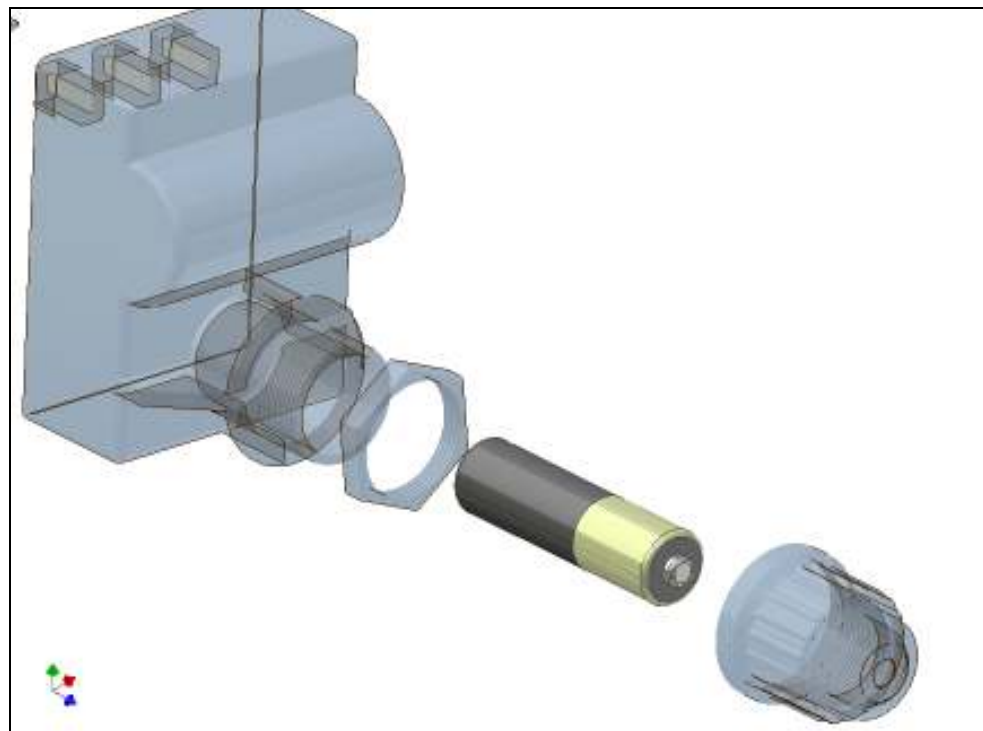

Fig 4.